

IMPLEMENTATION OF WIRELESS EV CHARGING WITH AUTO-PAYMENT DEDUCTION SYSTEM

Prof. Chandrapal Raut¹, Chandrashekhar Burde², Nandini Kahalkar², Bharti Hukare², Devendra Dhakate²

¹Assistant Professor, Department of Electronics and Telecommunication, Smt. Radhikatai Pandav College of Engineering, Nagpur, Maharashtra, India

²B.Tech Students, Department of Electronics and Telecommunication, Smt. Radhikatai Pandav College of Engineering, Nagpur, Maharashtra, India

ABSTRACT

As electric vehicle (EV) adoption continues to expand globally, the demand for efficient, reliable, and intelligent charging infrastructure is rapidly increasing. Conventional wired charging and manual billing system often create operational delays and limit transparency. This research presents a Wireless EV Charging System integrated with an automated auto-payment deduction framework to enhance convenience and efficiency.

The proposed system utilizes inductive power transfer technology to enable contactless energy transmission between transmitter and receiver coils. An embedded controller monitor voltage, current and charging parameter to ensure stable and safe operation. The integrated authentication and billing module calculates energy consumption in real time and perform automatic payment deduction, eliminating manual intervention.

By combining power electronics control, sensing mechanisms, and IoT-based communication, the system ensures secure transactions, improved energy efficiency and operational transparency. Overall, the proposed model offers a scalable and sustainable solution for next – generation smart EV charging infrastructure.

Keywords: Wireless EV charging, Inductive Power Transfer, Auto-Payment System, IoT, Smart Charging Infrastructure.

INTRODUCTION

Electric vehicles (EVs) are becoming more popular because they reduce pollution and save fuel. Many governments support because Electric vehicle adoption to create a clean angreen environment. As the No. of EVs increasing day by day, the need for better and faster charger also growing.

Nowadays, most EV charging stations use wired charging, where a cable is connected to the vehicle. This method can take time and may cause problem such as cable damage and manual effect. In addition, users have to make payment manually, which can create delays and inconvenience.

This paper introduces a wireless EV charging system with automatic payment deduction. In this system, electricity is transferred from a charging pad to the vehicle without physical cable. The power transfer works on the principle of electromagnetic induction using transmitter and receiver coils.

The system also includes an RFID-based identification module that detects the vehicle automatically. Once the vehicle is identified, the system checks available balance and starts charging if sufficient balance is present. The energy consumption is continuously monitored, and the corresponding amount is automatically deducted from the user's account. This ensures transparent and accurate billing without manual intervention.

In the future, such smart charging system can play important role in the development of smart cities. Wireless charging can be installed in highways, parking areas, Bus stop, residential societies to provide seamless charging experience. The system can also be integrated with mobile applications, renewable energy sources such as solar polar and advance technologies like artificial intelligence and IoT for better energy management. With further development, this technology can make EV charging fully automated, efficient and user-friendly.

LITERATURE SURVEY

We have studied earlier research papers to gain a clear understanding of the system we aim to develop. The following researchers offer useful insights into wireless EV charging and the integration of real-time payment features:

The study reviews static wireless EV charging system based on wireless power transfer (WPT) and electromagnetic induction highlighting, system efficiency, architecture and implementation challenges in wireless EV charging infrastructure. [1]

This paper presents real time wireless EV charging system is controlled using an Arduino microcontroller based on mutual induction and resonance coupling . [2]

The study explain a wireless EV charging system integrated with a real time payment gateway, enabling smooth authentication, automatic billing, and secure and safe transaction during the charging process. [3]

This paper presents on IoT based EV charging system that provides real time monitoring of energy consumption and transparent billing mechanism to enhance operation efficiency and user convenience. [4]

The study implements an automatic billing system for EV charging using IoT technology where charging data is securely recorded and shared to transparent, temper-proof billing and prevent post charging record manipulation. [5]

This paper study a wireless EV charging station integrated with a billing display system, where charging displayed and data monitoring using IoT based framework to transparent billing and controlled the date management. [6]

The study highlights an EV charging station integrated with UPI based real-time payment service, instant , enabling secure, contactless transactions through QR code scanning and Banking System. [7]

This paper presents an automatic EV charging station integrated with a battery management system and a payment gateway for secure transaction processing. [8]

The study implements a solar – powered wireless EV charging system that enables on road charging using solar panels and power conversion units focusing on the renewable energy integration. [9]

This paper demonstrates a wireless EV charging system integrated with solar energy support RFID based user authentication, real time energy monitoring and automatic payment deduction using a microcontroller.[10]

GENERAL METHODOLOGY

As electric vehicles (EVs) continue to gain popularity, the demand for efficient, intelligent, and user-friendly charging infrastructure is increasing rapidly. Conventional wired charging system often required manual monitoring and separate billing processes, which can lead to inconvenience and operational delays. Moreover, many small charging station lack integrated smart payment system and renewable energy support. To address the limitations, the proposed system presents a Wireless EV Charging framework integrated with RFID-based authentication, automated payment deduction, real-time energy monitoring, and optional solar energy support.

The overall system operates through a structured sequence of processes. Initially, each user provided with a unique RFID card linked to their register account. When the vehicle is positioned over the charging pad, the RFID reader scans the card and verifies user authorization through the microcontroller unit (ESP32/Arduino). Upon successful authentication, the system enables the charging module. The wireless power transfer mechanism operates based on electromagnetic. Induction, where alternating current supplied to the transmitter coil generates a magnetic field that induces voltage in the receiver coil mounted on the vehicle.

The induces AC power at the receiver side is rectified into DC and regulated to a suitable voltage level for battery charging. Simultaneously, voltage and current sensors continuously monitor energy consumption. The microcontroller calculates the total energy delivered in kilowatt- hours (kWh) and determines the corresponding cost based on a predefined tariff rate. The deducted amount is automatically updated in the user's account, ensuring transparent and accurate billing without manual intervention.

An LCD display module provides real – time information, including charging status, energy consumed, remaining balance, and system notification. Once the predefined energy limit or available balance is reached, the system automatically terminates

charging to prevent overuse. Additionally, to enhance sustainability, a solar panel subsystem can be integrated to store renewable energy in a battery bank during daytime operation. This stored energy can be utilized the EV charging, thereby reducing dependency on the conventional power grid.

This project has been implemented in two major parts, but the overall project works synchronously. Now, let’s explore each part in detail which contains several steps:

A. Wireless EV Charging System:

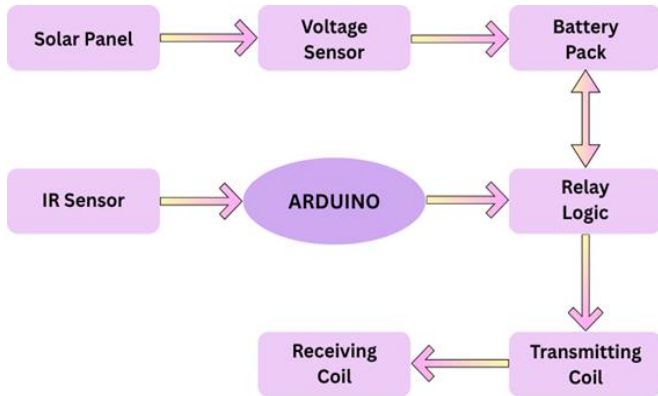

fig. a. Wireless EV Charging System

Step-1: Vehicle Detection:-

The IR sensor detects the presence of an electric vehicle when it is positioned over the charging pad. Once the vehicle is detected, a signal is sent to the Arduino controller.

Step-2: System initialization :-

After receiving the detected signal, the Arduino activates the system and check all components are functioning properly before starting the charging process.

Step-3: Power Generation :-

The solar panel generates DC electrical energy using sunlight. This energy acts as the primary power source for the charging system.

Step-4: Voltage Monitoring :-

The voltage sensor continuously measures the output voltage from the solar panel. This ensures that the voltage is within a safe and required range of battery charging.

Step-5: Relay Activation:-

If the voltage level is safe and the vehicle is detected, the Arduino sends a signal to the relay module. The relay switched ON the power supply to the transmitting circuit.

Step-6: Wireless Power Transfer:-

The transmitting coil produces an alternating electromagnetic field. Through inductive coupling, power is wirelessly transferred to the receiving coil installed in the electric vehicle.

Step-7: Battery Charging and Control:-

The receiving coil converts electromagnetic energy back into electrical energy and supplies it to the battery pack. The system continuously monitors the charging process and automatically stops when the battery reaches the desired level.

B. User Authentication and Auto-Payment Deduction System:

Let's discuss step-by-step working flow for the User Authentication and Auto-Payment Deduction System as shown in *fig. b.*:

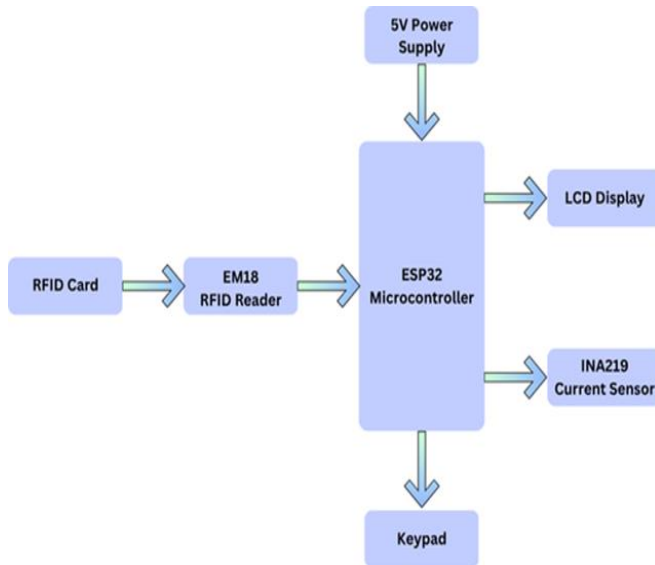

fig. b. User Authentication and Auto-Payment Deduction System

Step-1: Initialization:-

When powered ON, the ESP32 initializes the RFID reader, LCD, Keypad, INA219 current sensor, memory and relay module. Communication between components is established. The system checks readiness before operation.

Step-2: Standby Mode :-

After initialization, the system enters idle mode . The LCD displays “Scan RFID Card”. The relay remains OFF to prevent unauthorized charging.

Step-3: RFID Scanning:-

The user scans the RFID card near the EM18 reader. The reader captures the unique UID and sends it to the ESP32 for verification.

Step-4: User Authentication:-

The ESP32 compares the scanned UID with the stored database. IF invalid, access is denied. If valid, the system proceeds to balance retrieval.

Step-5: Balance Display:-

The available balance linked to the RFID card is retrieved from memory. The balance is displayed on the LCD for user confirmation.

Step-6: Charging Amount Input:-

The user enters the required charging amount using the keypad. The system validates the entered value before processing.

Step-7: Calculation:-

The system converts the entered amount into charging units based on the tariff rate (e.g. , 1 Units = 2 Rupees or 50 Units = 100 Rupees). This determine the charging duration.

Step-8: Balanced Verification and Recharge Option:-

The ESP32 checks whether sufficient balance is available. If the balance is insufficient, charging stopped and an “Insufficient Balance” message is displayed. In this case, the system allows the user to recharge the RFID account by adding funds. After successful recharge, the updated balance is displayed and the charging process can be restarted.

Step-9:Charging Activation and Monitoring :-

If sufficient balance is available, the relay turns ON and provides 12V DC output to start charging. The INA219 sensor monitors current and power consumption during operation.

Step-10: Auto cut-off:-

After the calculated units are delivered, the relay turns OFF automatically.

Step-11: Balance Update:

The deducted amount is updated in memory, and the remaining balance is displayed on the LCD.

RESULTS AND DISCUSSION

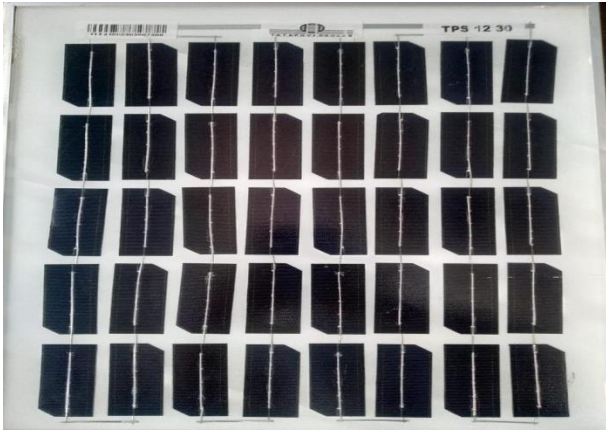

fig. c. Solar System



fig. d. Hardware Implementation of RFID based Wireless EV charging system

The implemented Wireless EV Charging System Successfully demonstrated efficient inductive power transfer without physical cable connection. Reliable energy transmission was achieved through properly aligned transmitter and receiver coils, validating the inductive coupling methodology.

The embedded controller (ESP32/Arduino) authenticated users via RFID scanning, ensuring secure and controlled access. After authentication, the system automatically calculated charging cost based on energy consumption and deducted the amount from the user's balance in real-time. The remaining balance was displayed, the charging stopped automatically when the balance became insufficient, allowing recharge when required.

During operation, voltage and system conditions were continuously monitored to enhance operational safety and efficiency. The design also incorporated optional renewable energy support (solar + battery), demonstrating feasibility for eco-friendly charging infrastructure.

The system provided transparent tracking of energy delivered and remaining balance. Due to its modular hardware and software architecture, the solution shows scalability for residential, public, and commercial deployment, offering a practical pathway toward next-generation smart EV charging system.

CONCLUSION

The study presents a practical and scalable Wireless EV Charging System integrated with RFID-based authentication and an automated payment deduction framework. The proposed system successfully demonstrated efficient inductive power transfer, secure user authentication, and real-time billing transparency, thereby enhancing operational efficiency and user convenience.

The integration of wireless power transfer with automated balance management ensures contactless charging, control access, and accurate cost calculation based on energy consumption. Automatic charging termination during insufficient balance further improves system reliability and accountability.

The results highlight the system's potential to contribute toward intelligent, secure and sustainable EV charging infrastructure. With its modular architecture and capability for renewable energy integration, the system can be extended for smart city

applications and large-scale deployment. Future research may focus on improving power transfer efficiency, optimizing alignment tolerance and implementing IoT-enabled remote monitoring for advance energy management.

REFERENCE

- [1]. V. Chauhan *et al.*, “A review of Static Wireless Electric Vehicle Charging System,” *International Journal of Scientific Research in Science, Engineering and Technology*, vol. 8, no.4, Apr.2023 .
- [2]. Jahnvi B. N. *et al.*, “Real Time Wireless Charging for EV Using Arduino Microcontroller,” *International journal of Creative Research Thoughts*, vol. 10, no.6, June2022.
- [3]. Bhagyashri Gangarde *et al.*, “Smart EV Charging Station with Automated Payment System,” *International Journal of Scientific Research in Science, Engineering and Technology*, vol. 12, no. 3, pp. 695–700, Jun. 2025.
- [4]. S. Dhivakar, S. Sarathkumar, R. Shanmughavalli, R. Mithish Kumar *et al.*, “Wireless EV charging Station with Real Rime Energy Monitoring and Management Using IoT,” *International Journal of Scientific Research in Engineering and Management*, vol.9, no.9, 1-9sept.2025.
- [5]. S Uthaya Selva Raja , J. Ramprabhu *et al.*, “Automatic Billing System For Electric Vehicle Charging,” *Turkish Journal of Computer and Mathematical Education*, vol. 12, no. 13, June2021, pp.5307-5310.
- [6]. Kalyani Ingale *et al.*, “Wireless Charging Station for EV vehicle with Billing Display,” *International Journal of Scientific Research in Science and Technology*, vol. 13, no. 4, Apr. 2024.
- [7]. Vaibhav Dange, Samarth Kore, Ritesh Kabra *et al.*, “Electric Vehicle Charging Station with UPI Payment Service,” *International Scientific Journal of Engineering and Management*, vol. 4, no. 6, June 2025.
- [8]. Shalom Richard Pakhare, Rizwan Balg, Abhishek Athani, Siddharth Mhade, Jayen Modi *et al.*, “Automatic Electric Vehicle Charging Station,” *Scholars Journal of Engineering and Technology*, vol. 12, no.1, pp. 1-18, Jan.2024.
- [9]. Roshan Ahire and Pooja Thombare *et al.*, “Solar Wireless Electric Vehicle Charging ,” *International Journal For Research in Applied Science and Engineering Technology (IJRASET)*, vol. 12, no. 10, Oct. 2024, pp. 476–479.
- [10]. Balamurali S, Jenith Kanna, Mithun Roshun R, Naresh Balaji S, Pravin U Set *et al.*, “Wireless Electric Vehicle Charging System ,” *Scholars Journal Of Engineering and Technology*, vol. 12, no. 1, pp. 1-18, Jan.2024.

Copyright & License:

© Authors retain the copyright of this article. This work is published under the Creative Commons Attribution 4.0 International License (CC BY 4.0), permitting unrestricted use, distribution, and reproduction in any medium, provided the original work is properly cited.